113023

FTL70G/G6

GAS GRIDDLE WITH SMOOTH PLATE (TOP VERSION)



- Gas griddle (70 cm top version) with a smooth steel cooking plate.
- Horizontal cooking plate (12 cm thick), 2 independent work areas.
- Heating through 2 steel burners (4 kW).
- Valved tap with maximum temperature of 390°C.
- Stainless steel control panel and side panels.
- Module coupling system with external side joints.
- Appliances intended for direct cooking.
- Cooking plate hermetically sealed to the worktop.
- Ignition through a piezoelectric device.
- Pilot burner and safety thermocouple.
- Grooving with a cap and removable drawer for collecting grease and liquids.
- Removable splashback on 3 sides integrated into the worktop.
- Plastic feet (H=51 mm).
- The gas appliances are CE-certified by German body DVGW and have passed the most stringent safety tests.
- The equipment is delivered in accordance with the customer's specifications in terms of installed nozzles, even during testing. G20 natural gas is the standard configuration. In addition, spare nozzles are included should conversion be necessary on site.

TECHNICAL DATA

TOTAL POWER	8 kW	GAS POWER	8 kW
NATURAL GAS CONSUMPTION	0,84 m³/h	COOKING SURFACE	69,6x52 cm
PLATE TYPE	Smooth	HEATING ZONES	n° 2
CE GAS CERTIFICATE NUMBER	CE-0085BO0093	GAS CONNECTION DIAMETER	1/2"G EN10226-1
GAS CONNECTION HEIGHT (H)	0 mm	GAS CONNECTION HEIGHT (X)	655 mm
GAS CONNECTION HEIGHT (Y)	-100 mm	FOOT HEIGHT	51 mm
WIDTH	70 cm	DEPTH	60 cm
HEIGHT	30 cm	PACKAGE WIDTH	76,0 cm
PACKAGE DEPTH	71,0 cm	PACKAGE HEIGHT	53,0 cm
NET WEIGHT	52,5000 kg	GROSS WEIGHT	58 kg
VOLUME	0,2900 m³	HARMONISED CODE	84198180
LPG CONSUMPTION	0.63 m³/h	LATENT HEAT RELEASE	3200.0 W
SENSIBLE HEAT RELEASE	2800.0 W	STEAM RELEASE	4704.0 g/h

ACCESSORIES

- 120591 PAIR OF JOINTS FOR GAS GRIDDLES
- 120595 GRIDDLE-CLEANING SCRAPER
- 120597 SCRAPER - SPARE BLADE KIT (10 PCS)

INSTALLATION SCHEMES

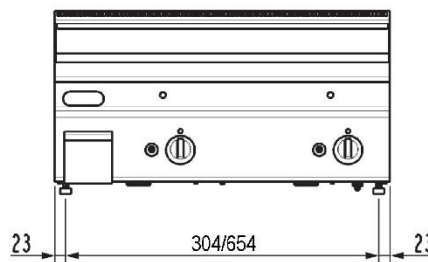
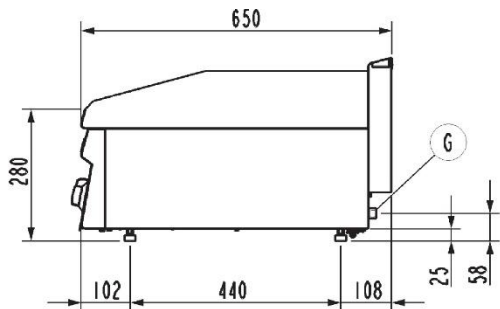

FT...G/O

G ISO 7-1 R 1/2"
ISO 228/1 G 1/2"

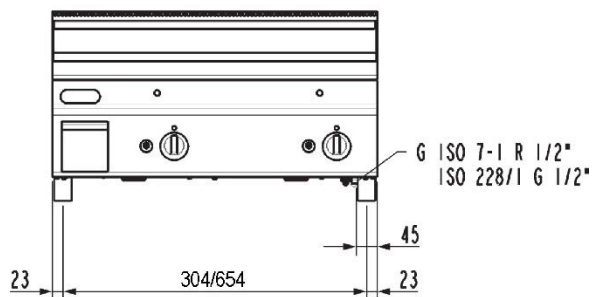
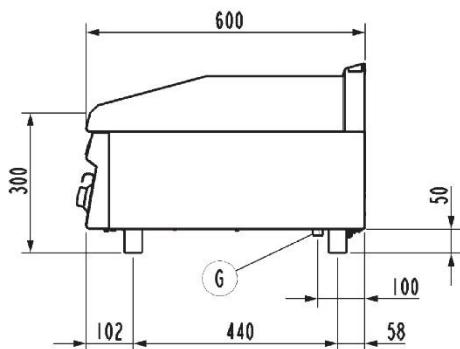
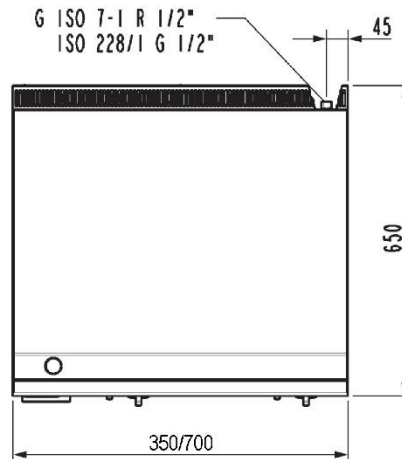

FT...G/G6

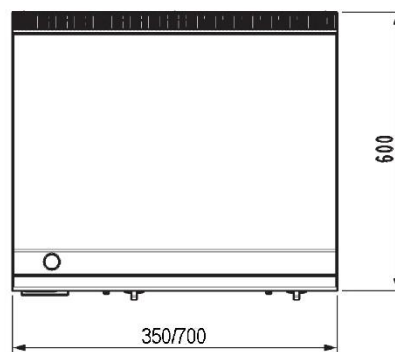

G (½"ISO228-1 – G ½" EN 10226-1) = Attacco gas | Gas inlet connection | Gasanschluss | Подсоединение газ | Arrivie gaz | Entrada gas.

Fig.1 | Abb.1 | рис.1 - 5415.680.00