113045**FTR35G/G6/B****GAS GRIDDLE WITH BRUSHED, CHROME-PLATED,
RIBBED PLATE (TOP VERSION)**



- Gas griddle (35 cm top version) with a brushed, chrome-plated ribbed cooking plate to cook a variety of products, from meat to fish and vegetables.
- Horizontal cooking plate (12 cm thick).
- The anti-scratch cooking plate ensures resistance to scratches and corrosion, while the striping enhances product grilling.
- The non-stick cooking plate ensures quick and effortless cleaning, prevents oxidation, and eliminates any flavour transfer.
- The chrome-plated surface ensures less energy consumption and heat dispersion.
- Heating through 1 steel burner (4 kW).
- Operating thermostatic valve with temperature ranging between 150°C and 300°C.
- Safety thermostat that triggers below 350°C.
- Chrome-plated griddles comply with EU Regulation 1935/2004 concerning food contact materials and articles which are intended to come into contact with food.
- Stainless steel control panel and side panels.
- Module coupling system with external side joints.
- Appliances intended for direct cooking.
- Cooking plate hermetically sealed to the worktop.
- Ignition through a piezoelectric device.
- Pilot burner and safety thermocouple.
- Grooving with a cap and removable drawer for collecting grease and liquids.
- Removable splashback on 3 sides integrated into the worktop.
- Plastic feet (H=51 mm).
- The gas appliances are CE-certified by German body DVGW and have passed the most stringent safety tests.
- The equipment is delivered in accordance with the customer's specifications in terms of installed nozzles, even during testing. G20 natural gas is the standard configuration. In addition, spare nozzles are included should conversion be necessary on site.

TECHNICAL DATA

TOTAL POWER	4 kW	GAS POWER	4 kW
TEMPERATURE RANGE	60÷300 °C	NATURAL GAS CONSUMPTION	0,42 m³/h
COOKING SURFACE	34,6x52 cm	PLATE TYPE	Brushed chrome-plated - ribbed
HEATING ZONES	n° 1	CE GAS CERTIFICATE NUMBER	CE-0085B00093
GAS CONNECTION DIAMETER	1/2"G EN10226-1	GAS CONNECTION HEIGHT (H)	0 mm
GAS CONNECTION HEIGHT (X)	305 mm	GAS CONNECTION HEIGHT (Y)	-100 mm
FOOT HEIGHT	51 mm	IPX RATING	4
WIDTH	35 cm	DEPTH	60 cm
HEIGHT	30 cm	PACKAGE WIDTH	71,0 cm
PACKAGE DEPTH	41,0 cm	PACKAGE HEIGHT	53,0 cm
NET WEIGHT	22,0000 kg	GROSS WEIGHT	27,0000 kg
VOLUME	0,1500 m³	HARMONISED CODE	84198180
LPG CONSUMPTION	0.32 m³/h	LATENT HEAT RELEASE	1600.0 W
SENSIBLE HEAT RELEASE	1400.0 W	STEAM RELEASE	2352.0 g/h

ACCESSORIES

- 120591 PAIR OF JOINTS FOR GAS GRIDDLES
- 120595 GRIDDLE-CLEANING SCRAPER
- 120597 SCRAPER - SPARE BLADE KIT (10 PCS)

INSTALLATION SCHEMES

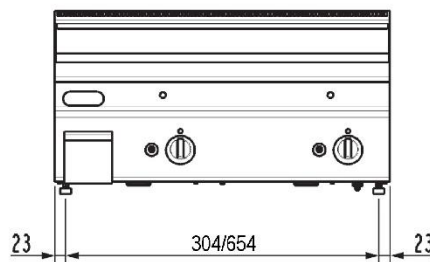
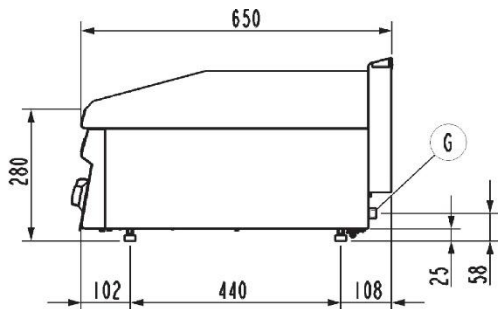

FT...G/O

G ISO 7-1 R 1/2"
ISO 228/1 G 1/2"

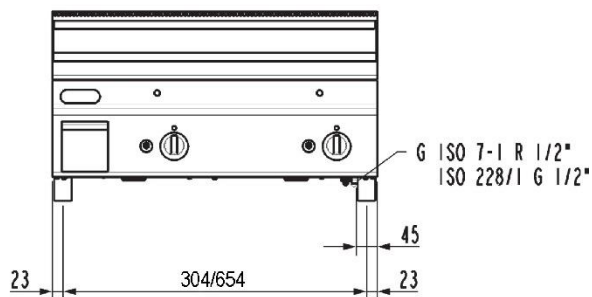
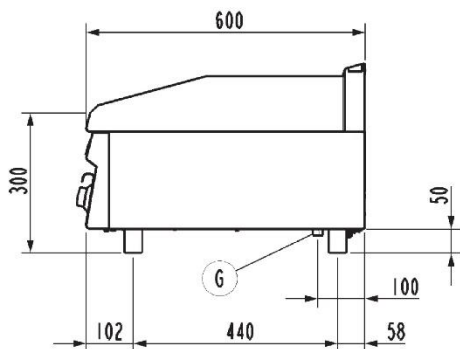
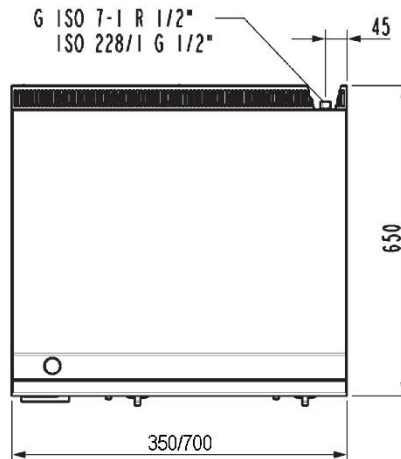

FT...G/G6

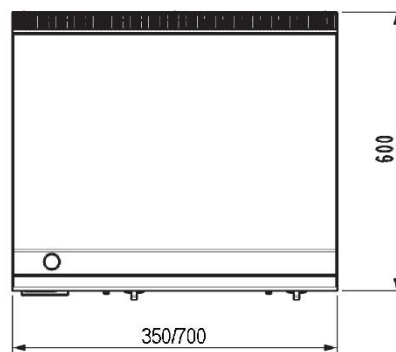

G (1/2"ISO228-1 – G 1/2" EN 10226-1) = Attacco gas | Gas inlet connection | Gasanschluss | Подсоединение газ | Arrivie gaz | Entrada gas.

Fig.1 | Abb.1 | рис.1 - 5415.680.00