

---

**123022**

FTC35G/0

**GAS GRIDDLE WITH CHROME-PLATED, SMOOTH PLATE (TOP VERSION)**

---



- Gas griddle (35 cm top version) with a mirror-polished, brushed, chrome-plated, smooth plate top recommended for cooking delicate foods like fish and vegetables.
- Horizontal cooking plate (12 cm thick).
- The non-stick cooking plate ensures quick and effortless cleaning, prevents oxidation, and eliminates any flavour transfer.
- Heating through 1 steel burner (4 kW).
- Operating thermostatic valve with temperature ranging between 150°C and 300°C.
- Safety thermostat that triggers below 350°C.
- Scraper included.
- Height-adjustable rubberised plastic feet (15-25 mm).
- Chrome-plated griddles comply with EU Regulation 1935/2004 concerning food contact materials and articles which are intended to come into contact with food.
- Stainless steel control panel and side panels.
- Module coupling system with external side joints.
- Appliances intended for direct cooking.
- Cooking plate hermetically sealed to the worktop.
- Ignition through a piezoelectric device.
- Pilot burner and safety thermocouple.
- Grooving with a cap and removable drawer for collecting grease and liquids.
- Removable splashback on 3 sides integrated into the worktop.
- Height-adjustable rubberised plastic feet (15-25 mm).
- Technical compartment to facilitate connection to the gas network.
- The gas appliances are CE-certified by German body DVGW and have passed the most stringent safety tests.
- The equipment is delivered in accordance with the customer's specifications in terms of installed nozzles, even during testing. G20 natural gas is the standard configuration. In addition, spare nozzles are included should conversion be necessary on site.

---

**TECHNICAL DATA**

TOTAL POWER	4 kW	GAS POWER	4 kW
TEMPERATURE RANGE	60÷300 °C	NATURAL GAS CONSUMPTION	0,42 m³/h
COOKING SURFACE	34,6x56,4 cm	PLATE TYPE	Chrome-plated - smooth
HEATING ZONES	n° 1	CE GAS CERTIFICATE NUMBER	CE-0085B00093
GAS CONNECTION DIAMETER	1/2"G EN10226-1	GAS CONNECTION HEIGHT (H)	33 mm
GAS CONNECTION HEIGHT (X)	305 mm	GAS CONNECTION HEIGHT (Y)	-50 mm
FOOT HEIGHT	25 mm	FOOT ADJUSTMENT	25/35 mm
WIDTH	35 cm	DEPTH	65 cm
HEIGHT	28 cm	PACKAGE WIDTH	71,0 cm
PACKAGE DEPTH	41,0 cm	PACKAGE HEIGHT	53,0 cm
NET WEIGHT	31,2 kg	GROSS WEIGHT	36,2 kg
VOLUME	0,1500 m³	HARMONISED CODE	84198180
LPG CONSUMPTION	0.32 m³/h	LATENT HEAT RELEASE	1600.0 W
SENSIBLE HEAT RELEASE	1400.0 W	STEAM RELEASE	2352.0 g/h

---

**ACCESSORIES**

- 120590 PAIR OF JOINTS FOR GRIDDLES
- 120595 GRIDDLE-CLEANING SCRAPER
- 120597 SCRAPER - SPARE BLADE KIT (10 PCS)

INSTALLATION SCHEMES

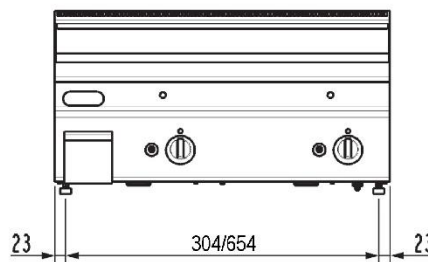
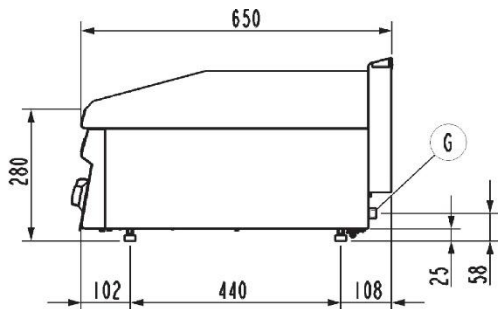

G ISO 7-1 R 1/2"  
ISO 228/1 G 1/2"

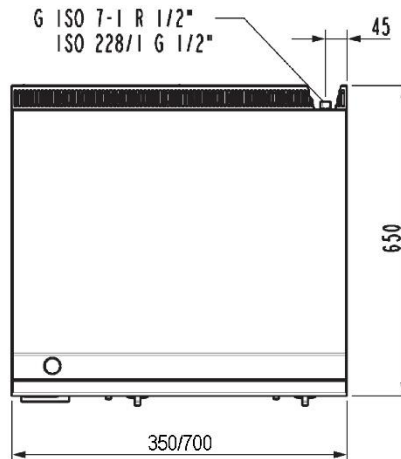

**FT...G/O**

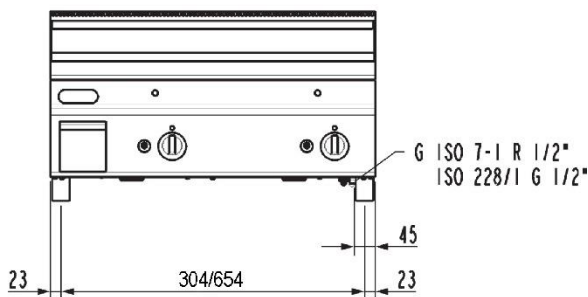
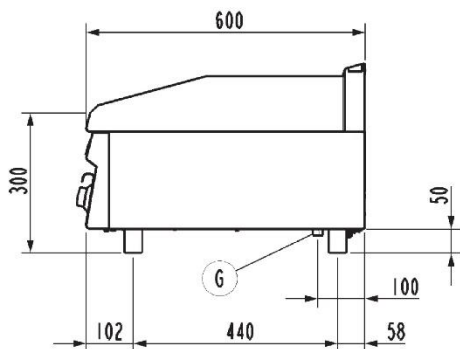

G ISO 7-1 R 1/2"  
ISO 228/1 G 1/2"

**FT...G/G6**

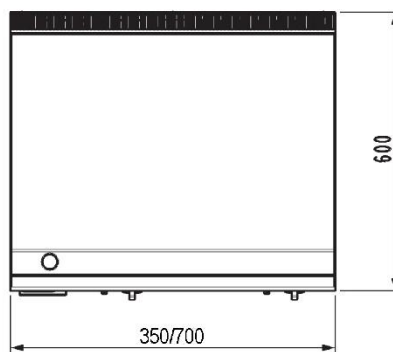

G (1/2"ISO228-1 – G 1/2" EN 10226-1) = Attacco gas | Gas inlet connection | Gasanschluss | Подсоединение газ | Arriviee gaz | Entrada gas.

Fig.1 | Abb.1 | рис.1 - 5415.680.00