

316095

P85FIE9

FREESTANDING ELECTRIC BOILING PAN 150L WITH INDIRECT HEATING AND AISI 316 STAINLESS STEEL TANK



- Electric indirect heat boiling pan with a 150 L capacity tank.
- AISI 304 stainless steel 2mm thick worktop and Scotch Brite finish with internal side-by-side joining system.
- AISI 304 stainless steel control panel and side panels.
- Indirect heat boiling pans are suitable for cooking dense or gelatinous foods as well as for immersion cooking.
- AISI 304 stainless steel tank walls and AISI 316 bottom (2 mm thick).
- Heating through armoured heating elements in Incoloy alloy inside the jacket.
- Jacket with pressure gauge, 0.5 bar safety valve and cap for filling distilled water.
- The appliance is equipped with a three-position selector switch: position 0: Off; position 1: Power reduced by 50%; position 2: Maximum power (100%).
- Operating thermostat that adjusts the temperature inside the cooking tank 0-40-60-80-100°C.
- Green light indicating voltage presence.
- Orange light indicating that the heating elements are heating up.
- Safety thermostat automatically stops operation in the presence of a fault.
- Stainless steel, hinged, spring-balance lid in all opening positions with heat-resistant handle.
- Mixing tap for hot and cold water, fixed at the worktop rear.
- Chrome-plated brass tank drain tap with heat-resistant handle on front panel.
- AISI 304 height-adjustable feet (133/195 mm).

TECHNICAL DATA

TOTAL POWER	18 kW	ELECTRIC POWER	18 kW
FREQUENCY	50/60 Hz	VOLTAGE	400 3N ~ V
TANK CAPACITY	150lt	TANK DIMENSIONS	Ø60xh54 cm
HEATING	Indirect	MINIMUM POWER CABLE CROSS-SECTION	5 x 6 n° - mm ²
ELECTRIC CABLE TYPE	H07 RN-F	TANK TYPE	AISI 316
WATER CONNECTION POSITION	Bottom	WATER CONNECTION DIAMETER	0,393701"
IPX RATING	4	WIDTH	80 cm
DEPTH	90 cm	HEIGHT	90 cm
PACKAGE WIDTH	109,0 cm	PACKAGE DEPTH	87,0 cm
PACKAGE HEIGHT	117 cm	NET WEIGHT	156,0000 kg
GROSS WEIGHT	178,0000 kg	VOLUME	1,10 m ³
HARMONISED CODE	84198180		

ACCESSORIES

- 399513 DOUBLE PASTA BASKET FOR 150L BOILING PAN - 3MM HOLE DIAMETER - 0.12 IN
- 399514 DOUBLE BASKET FOR VEGETABLES FOR BOILING PAN 150LT - HOLES DIAMETER 5MM - 0.20 INCH
- 399573 PAIR OF CLOSING ELEMENTS FOR BASES AND WORKTOPS (L=90CM)
- 399575 AUTOMATIC DOUBLE-JACKET WATER CHARGE

INSTALLATION SCHEMES

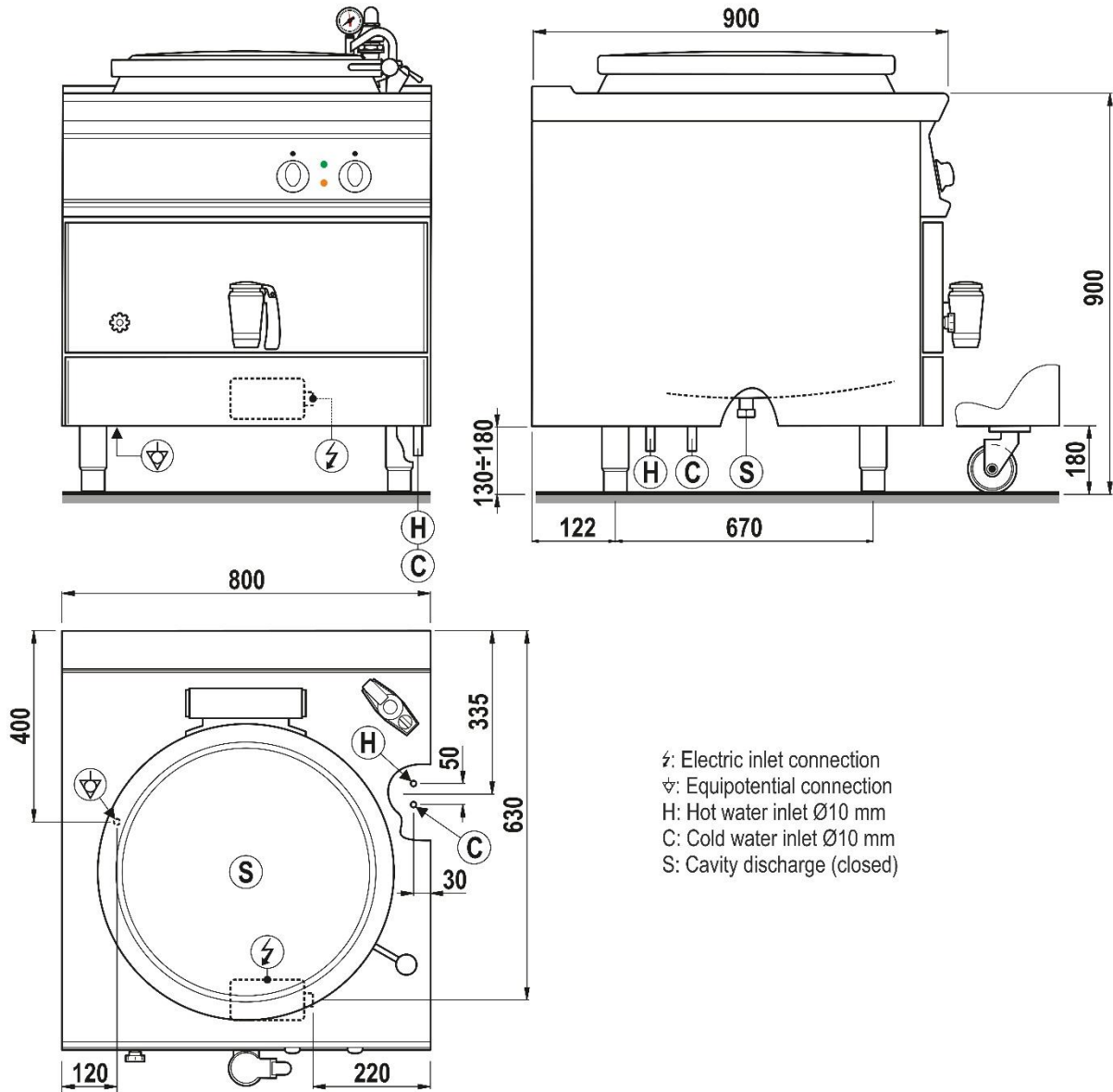

Fig.1 | Abb.1 | рис.1 - 09.04.2021 - 5415.643.00