616044

SP35E7

GN1/1 ELECTRIC CHIP SCUTTLE (TOP VERSION)



- GN 1/1 electric chip scuttle (35 cm top version).
- Stainless steel control panel, side and back panels.
- Module coupling system with external side joints.
- Heating through a lamp with ceramic-cast infrared heating element.
- Included with a removable (GN 1/1 H 150 mm) container with false bottom for oil dripping, both in AISI 304 stainless steel.
- Energy regulator 1-6-Infinite.
- Height-adjustable rubberised plastic feet (15-25 mm).
- Technical compartment for easy connection to the electrical network.

TECHNICAL DATA

TOTAL POWER	1 kW	ELECTRIC POWER	1 kW
FREQUENCY	50/60 Hz	VOLTAGE	220-240 ~ V
TANK CAPACITY	GN1/1	TANK DIMENSIONS	32,5x53x20 cm
MINIMUM POWER CABLE CROSS-SECTION	3 x 1,5 n° - mm ²	ELECTRIC CABLE TYPE	H07 RN-F
TANK TYPE	AISI 304	ELECTRICAL CONNECTION HEIGHT (H)	21,5 mm
ELECTRICAL CONNECTION HEIGHT (X)	307 mm	ELECTRICAL CONNECTION HEIGHT (Y)	-78 mm
FOOT HEIGHT	15 mm	FOOT ADJUSTMENT	15/25 mm
IPX RATING	4	WIDTH	35 cm
DEPTH	70 cm	HEIGHT	28 cm
PACKAGE WIDTH	79 cm	PACKAGE DEPTH	45 cm
PACKAGE HEIGHT	59,0 cm	NET WEIGHT	13,5 kg
GROSS WEIGHT	18,8 kg	VOLUME	0,21 m ³
HARMONISED CODE	84198180		

ACCESSORIES

220585 JOINT

INSTALLATION SCHEMES

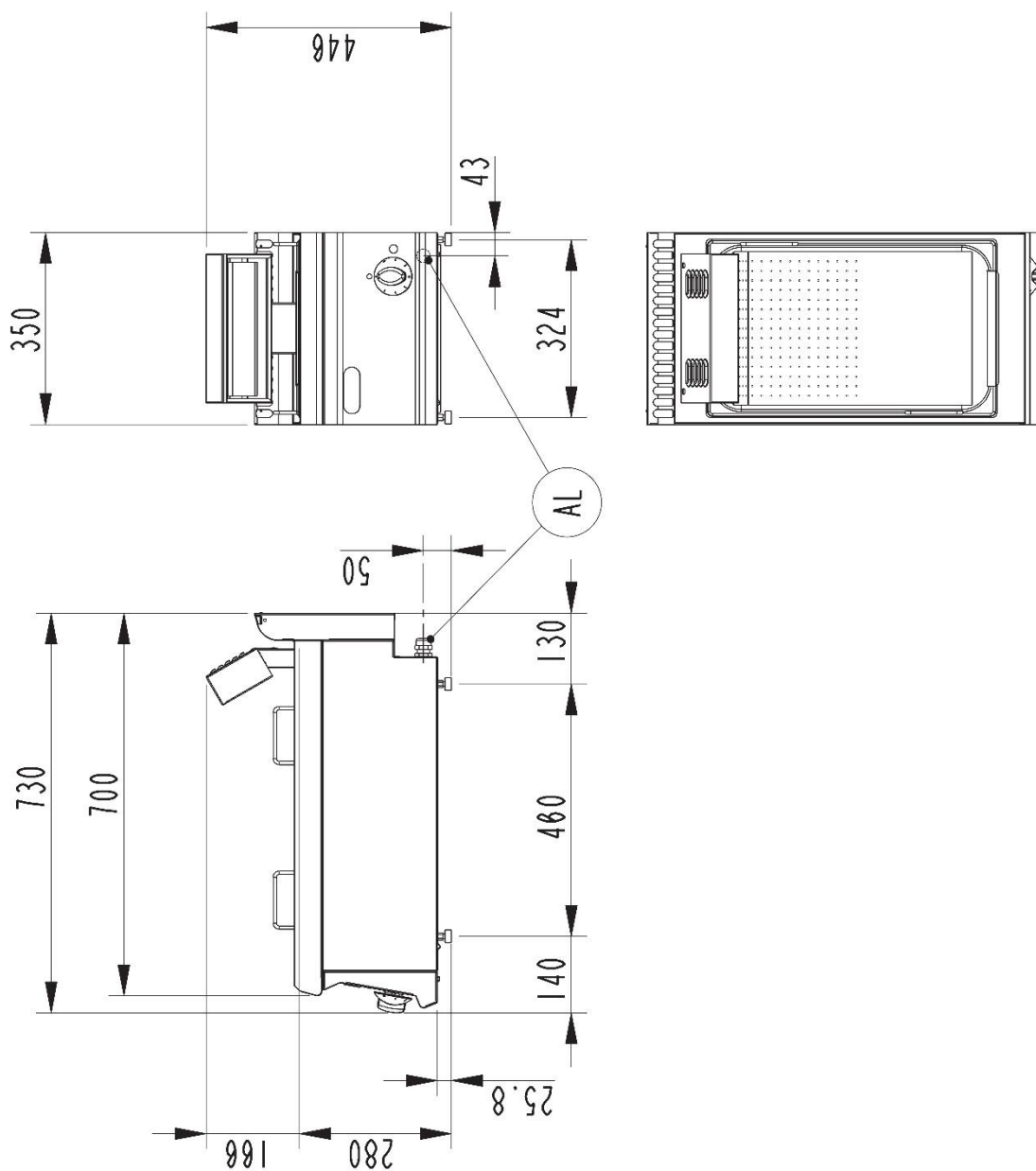

Fig.1 | Abb.1 | pvc.1 - 5415.663.00